



UNI-JET 40

0,2 kW (50 Hz)

0,25 kW (60 Hz)

Del presente modello sono disponibili anche le seguenti versioni speciali:

This model is also available with the following specifications:

- **ANODIZZATO** / ANODIZED TREATMENT

- a richiesta **TENSIONI SPECIALI** / SPECIAL VOLTAGES on request

MOTORI COSTRUITI SECONDO LE NORME CEI 2-3 (1988) ISOL. CL F PROT. IP 54

MOTORS CONSTRUCTION CONFORM WITH CEI 2-3 (1988) NORMS. ISOL. CL F PROT. IP 54

	ARTICOLO ITEM CODE	kW	V	Hz	assorb. AMP. absorbed. AMPS.	giri/min r.p.m.	LIMITE SERVIZIO MAX CONT. DUTY S1 mmH ₂ O	μF/V	dB (A)*	PESO Kg WEIGHT Kg
MONO-FASE SINGLE PHASE	014027	0,2	230	50	1,7	2900	-800 +900	4/450	57	7
	014037	0,25	220	60	2	3400	-1150 +1250	4/450	60	7
TRI-FASE THREE PHASE	014034	0,2	230 Δ 400 Y	50	1,3 0,75	2870	-800 +900		57	7
		0,25	265 Δ 460 Y	60	1,3 0,75	3450	-1150 +1250		60	7

* Livello di pressione sonora rilevato secondo le Norme ISO 3746 - 1979 (E). Parametri: r=1 - Rumore di fondo ≤ 51 dB (A) - Strumento: Brüel & Kjær type 2232.

* Sound pressure level tested according to ISO regulation 3746 - 1979 (E). Parameters: r=1 - Background noise ≤ 51 dB (A) - Instrument: Brüel & Kjær type 2232.

DIMENSIONI DIMENSIONS

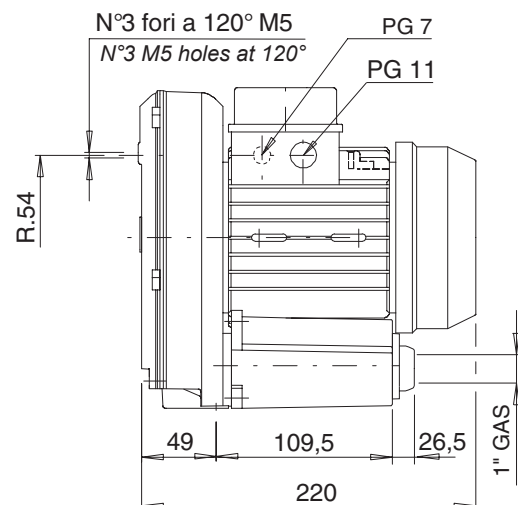
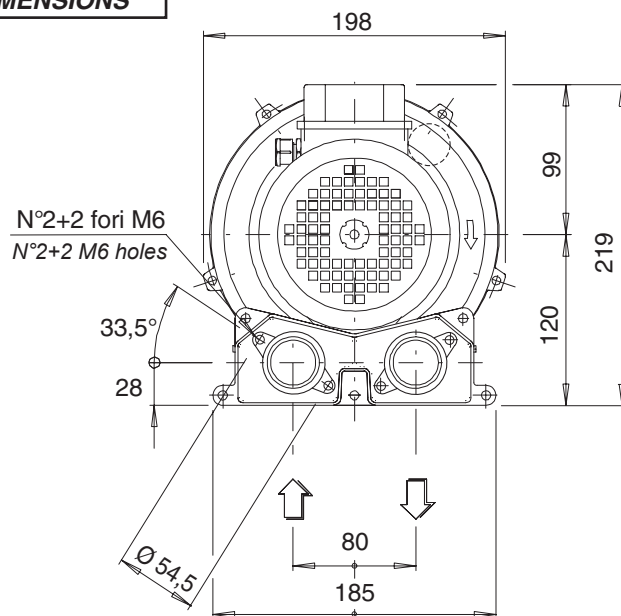

Le dimensioni di ingombro sono espresse in millimetri
All dimensions are in mm.

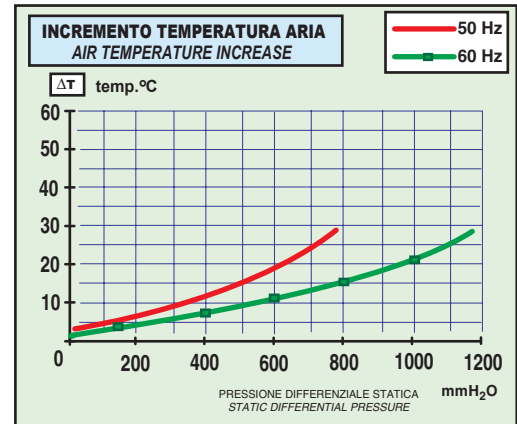
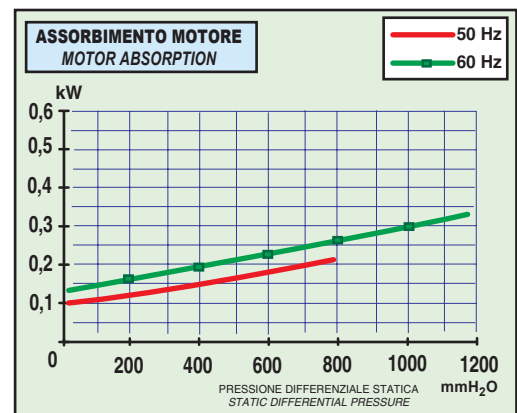
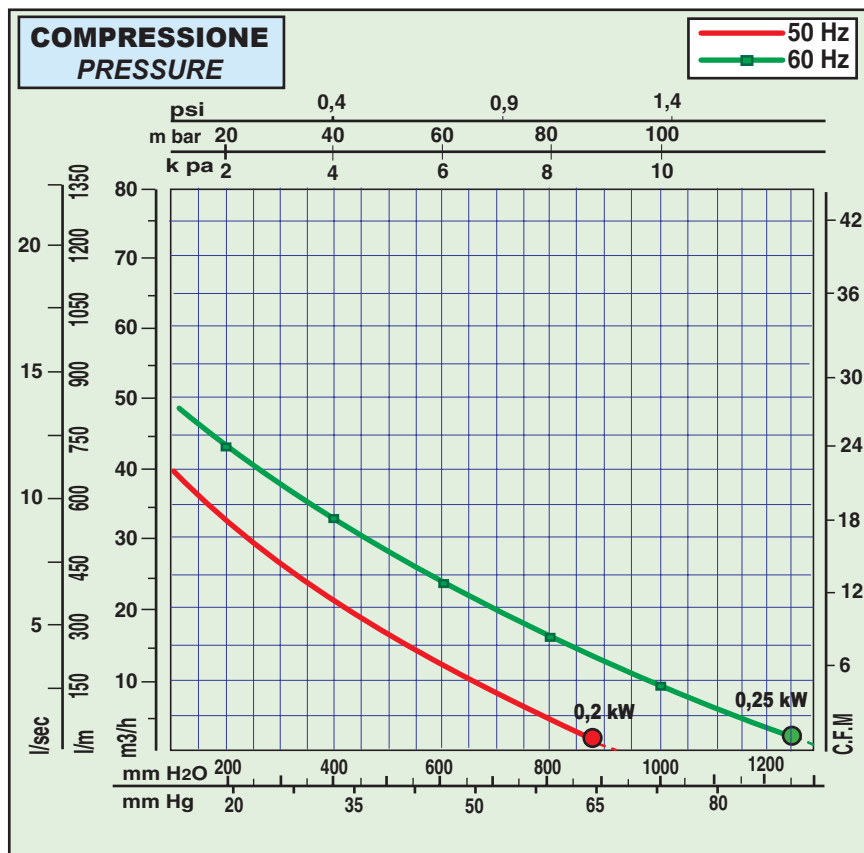
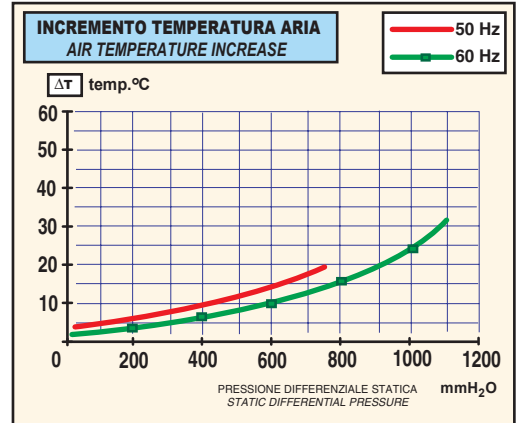
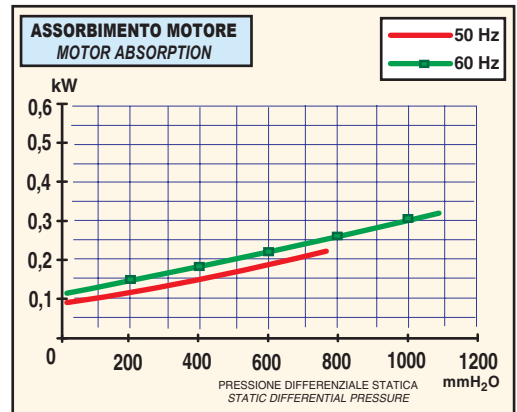
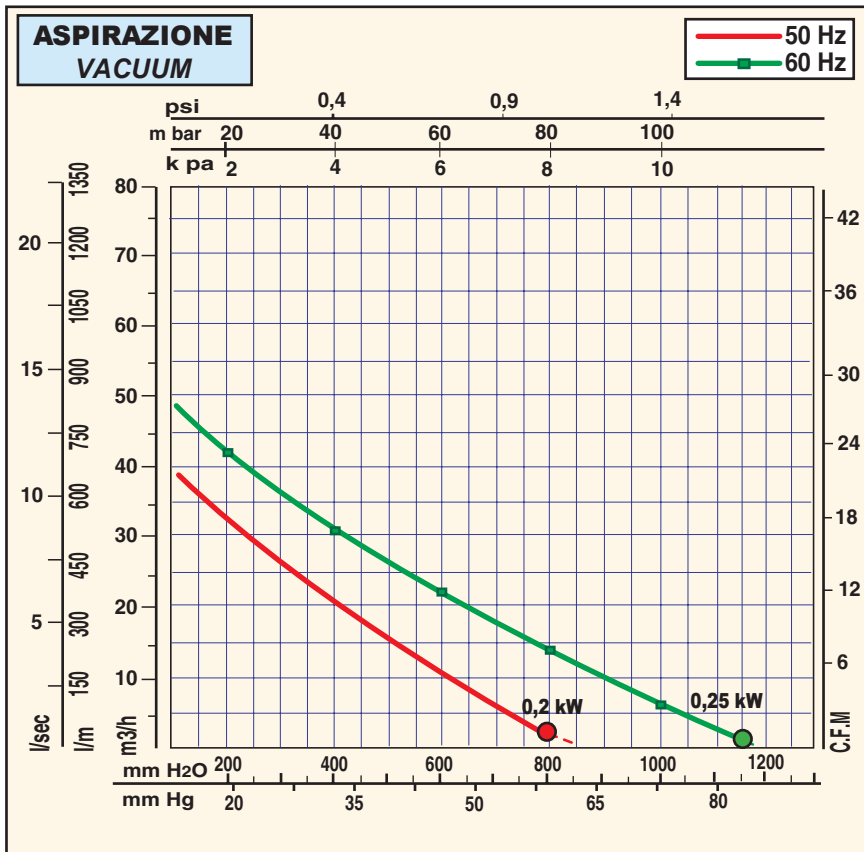

Tutti i dati della presente scheda tecnica si intendono indicativi e potranno essere modificati dalla casa in qualsiasi momento senza nessun preavviso.
 La curva di aspirazione è riferita ad aria alla temperatura media di 20 °C e 1013 mbar sul raccordo di mandata.
 La curva di compressione è riferita ad aria alla temperatura media di 20 °C e 1013 mbar sul raccordo di aspirazione.
 All data is intended as an indication and may be modified without prior notice.
 The vacuum curve is valid for pumping air, with a temperature of 20°C at the inlet flange and with a pressure of 1013 mbar at the discharge port.
 The pressure curve is valid for pumping air, with an average temperature of 20°C and 1013 mbar at the inlet flange.

 Valore max di pressione per servizio continuativo
Max value for continuous duty