

## FLUX-JET 2V

2,2 kW (50 Hz)  
2,6 kW (60 Hz)

Del presente modello sono disponibili anche le seguenti versioni speciali:

*This model is also available with the following specifications:*

- **LUBRIFICATO** per alte temperature / **LHT** Lubricated for high temperature
- a richiesta **TENSIONI SPECIALI** / **SPECIAL VOLTAGES** on request

MOTORI COSTRUITI SECONDO LE NORME CEI 2-3 (1988) ISOL. CL F PROT. IP 54  
MOTORS CONSTRUCTION CONFORM WITH CEI 2-3 (1988) NORMS. ISOL. CL F PROT. IP 54

ARTICOLO ITEM CODE	kW	V	Hz	assorb. AMP. absorbed. AMPS.	giri/min r.p.m.	LIMITE SERVIZIO MAX CONT. DUTY S1 mmH <sub>2</sub> O	μF/V	dB (A)*	PESO Kg WEIGHT Kg
<b>048150</b>	2,2	230 Δ	50	9	2850	-2350 +2700		72	31
		400 Y	50	5,2					
	2,6	265 Δ	60	9	3450	-2600 +2500		75	31
		460 Y	60	5,2					
<b>048161 LHT</b>	2,2	230 Δ	50	9	2850	-2700 +2700		72	31
		400 Y	50	5,2					
	2,6	265 Δ	60	9	3450	-2850 +2500		75	31
		460 Y	60	5,2					

THREE-PHASE

\* Livello di pressione sonora rilevato secondo le Norme ISO 3746 - 1979 (E). Parametri: r=1 - Rumore di fondo ≤ 51 dB (A) - Strumento: Brüel & Kjær type 2232.  
\* Sound pressure level tested according to ISO regulation 3746 - 1979 (E). Parameters: r=1 - Background noise ≤ 51 dB (A) - Instrument: Brüel & Kjær type 2232.

### DIMENSIONI DIMENSIONS

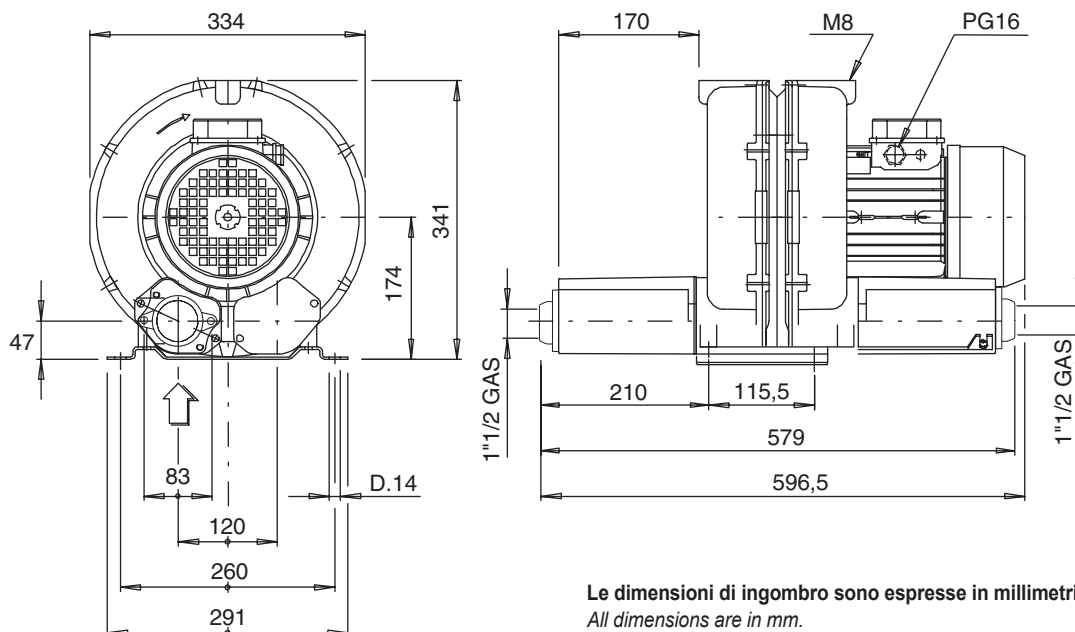

Le dimensioni di ingombro sono espresse in millimetri  
All dimensions are in mm.

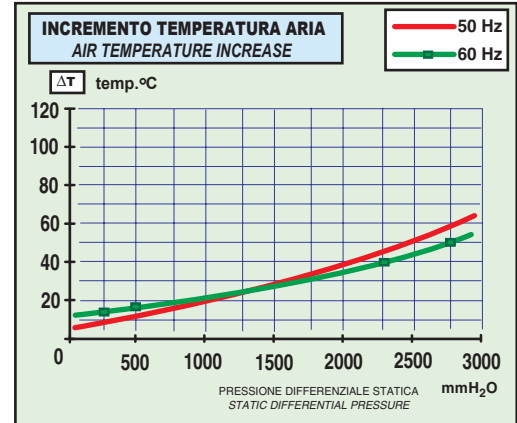
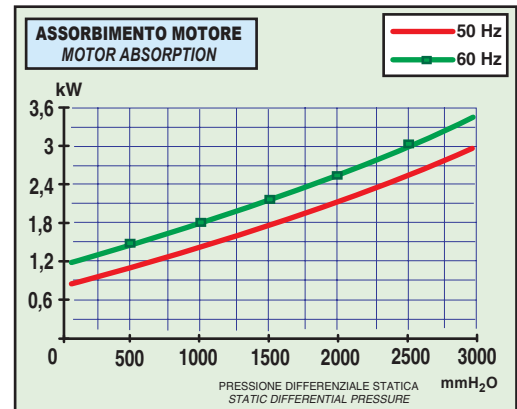
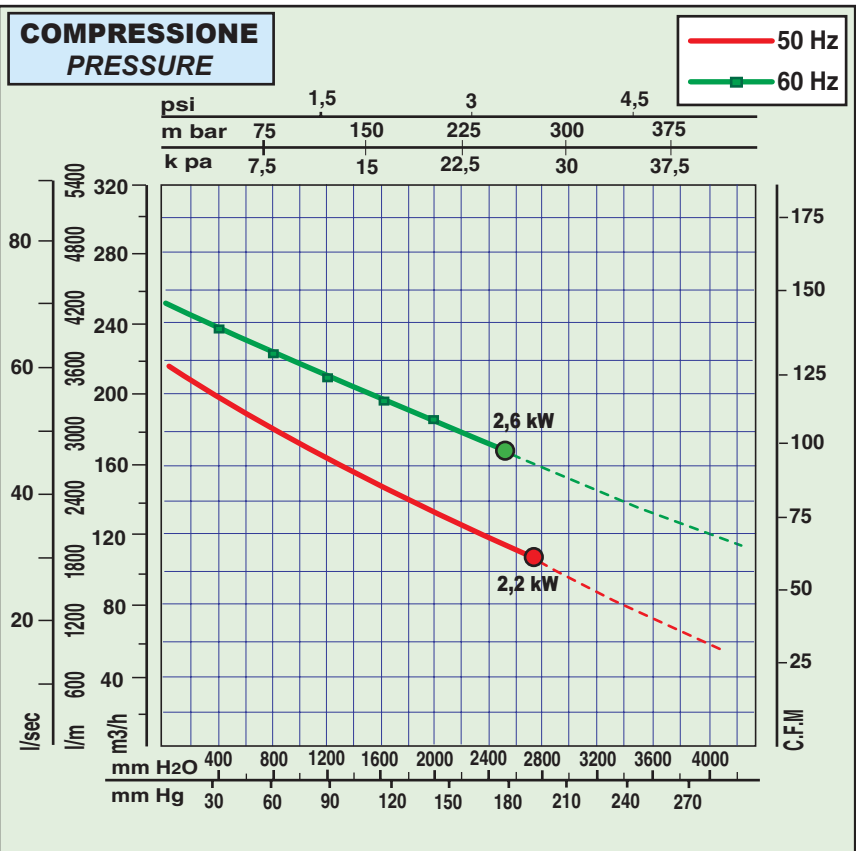
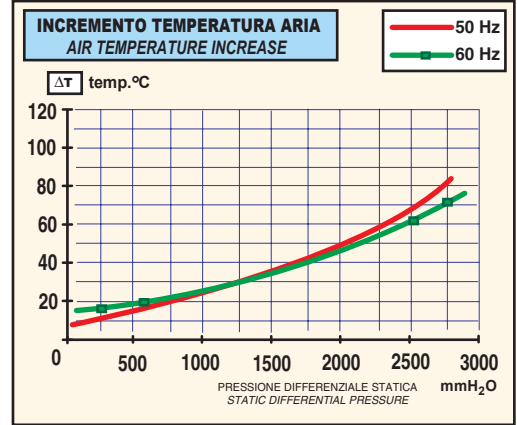
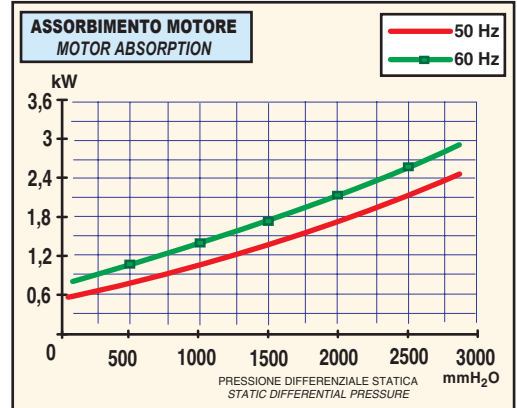
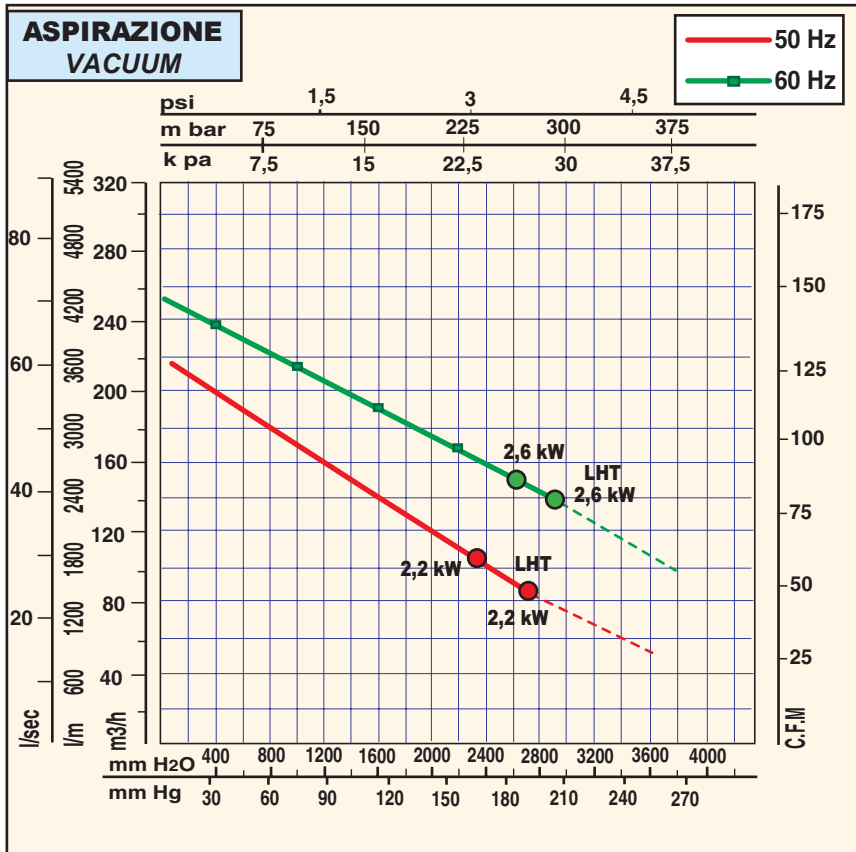

Tutti i dati della presente scheda tecnica si intendono indicativi e potranno essere modificati dalla casa in qualsiasi momento senza nessun preavviso.  
 La curva di aspirazione è riferita ad aria alla temperatura media di 20 °C e 1013 mbar sul raccordo di mandata.  
 La curva di compressione è riferita ad aria alla temperatura media di 20 °C e 1013 mbar sul raccordo di aspirazione.  
 All data is intended as an indication and may be modified without prior notice.  
 The vacuum curve is valid for pumping air, with a temperature of 20°C at the inlet flange and with a pressure of 1013 mbar at the discharge port.  
 The pressure curve is valid for pumping air, with an average temperature of 20°C and 1013 mbar at the inlet flange.

 Valore max di pressione per servizio continuativo  
Max value for continuous duty