

General

Model: centrifugal ventilator. The robust ventilator body is made of die-cast aluminium alloy and is coated. Asynchronous motor fitted with long-life ball bearings. Provided with removable baseplate and protection grid at inlet.

Application

Suitable for transport of clean and dusty gasses without abrasive particles and with a temperature limited to 80°C.

Algemeen

Type: centrifugaalventilator. Het robuuste ventilatorhuis is gemaakt uit gietaluminium en voorzien van een solide coating. De asynchrone motor is voorzien van duurzame kogellagers. De voet is demontabel en de inlaat voorzien van een rooster.

Toepassing

Inzetbaar voor transport van schone en vervuilde gassen, zonder schurende stoffen, met een maximum tempera-



Technical data

Power	Vermogen	0.05	kW
Voltage 1~	Spanning 1~	230	V
3~	3~	230/400	V
Current 1~	Stroom 1~	1.0	A
3~	3~	0.5/0.28	A
Frequency	Frequentie	50	Hz
Revolutions	Toerental	2800	/min
Protection class	Bescherming	IP 20	
Noise level	Geluidsniveau	45	dB
Weight	Gewicht	4.7	kg
Positions	Posities	1,3,5,7	

Technische gegevens

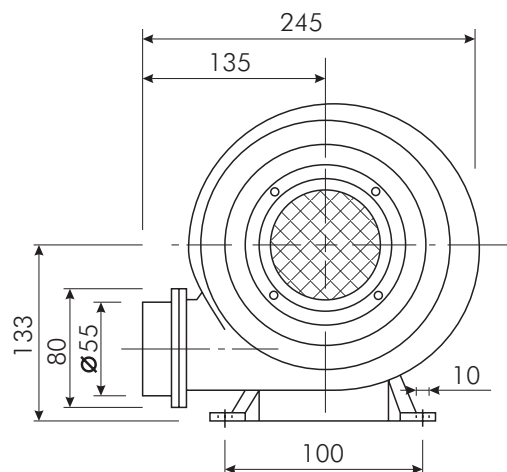
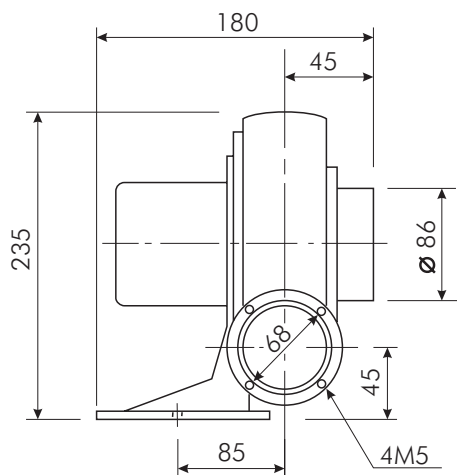
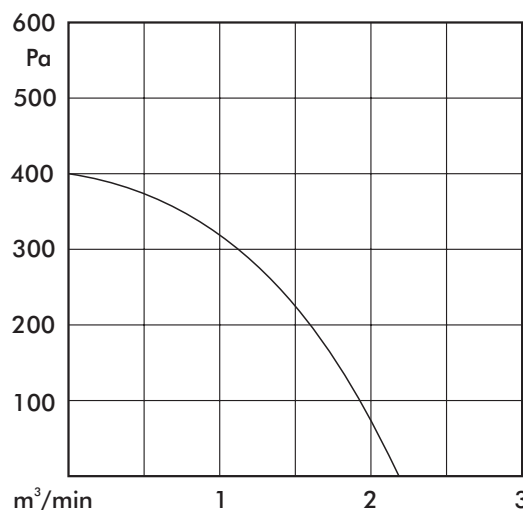

Dimensions in mm

Maten in mm